

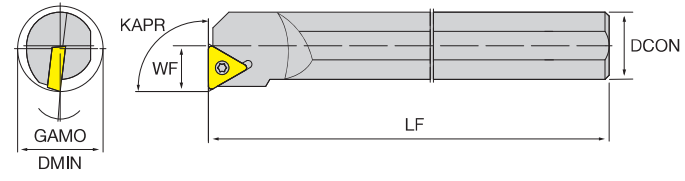

<h1 style="margin: 0;">S STFC</h1>	<p>STEEL Right-hand shown</p> 	
<p>ISO - TC</p> <ul style="list-style-type: none"> • Internal turning (KAPR 91°) • Steel boring bar without internal coolant • Holds TC-style inserts, tightened by screws 		

Designation	Stock		DMIN	DCON	WF	LF	LH	LPR	KAPR	GAMO	MIID
	L	R									
NT-S08H-STFC ¹ /r09	○	○	12	8	6	100	-	-	91°	15°	TC ₀₀ 0902 ₀₀
NT-S10K-STFC ¹ /r09	○	○	14	10	7	125	-	-	91°	15°	TC ₀₀ 0902 ₀₀
NT-S12M-STFC ¹ /r09	○	○	16	12	9	150	-	-	91°	10°	TC ₀₀ 0902 ₀₀
NT-S10K-STFC ¹ /r11	●	●	14	10	7	125	-	-	91°	12°	TC ₀₀ 1102 ₀₀
NT-S12M-STFC ¹ /r11	●	●	14	12	7	150	-	-	91°	10°	TC ₀₀ 1102 ₀₀
NT-S16Q-STFC ¹ /r11	●	●	18	16	9	180	-	-	91°	8°	TC ₀₀ 1102 ₀₀
NT-S20R-STFC ¹ /r11	○	○	25	20	13	200	-	-	91°	3°	TC ₀₀ 1102 ₀₀
NT-S20R-STFC ¹ /r16	●	●	25	20	13	200	-	-	91°	8°	TC ₀₀ 16T3 ₀₀
NT-S25R-STFC ¹ /r16	●	●	32	25	17	200	-	-	91°	6°	TC ₀₀ 16T3 ₀₀
NT-S32S-STFC ¹ /r16	○	○	39	32	22	250	-	-	91°	4°	TC ₀₀ 16T3 ₀₀

● stock standard, ○ non-standard stock, ▲ upcoming introduction, ▽ stock exhaustion

Spare parts	Insert screws	Flag wrenches
		
NT-S ₀₀₀ -STFC ¹ /r09	NT-ST22049T07	NT-FT07
NT-S ₀₀₀ -STFC ¹ /r11	NT-ST25060T07	NT-FT07
NT-S ₀₀₀ -STFC ¹ /r16	NT-ST35089T15	NT-FT15

- A - TURNING
- B - THREADING
- C - GROOVING
- D - MILLING
- E - DRILLING
- F - ACCESSORIES
- G - SPARE PARTS